

CONTROL BLOCK FOR PACKING PRESSES



Characteristics

TYPE	SIZE (Bsp)	MAX. FLOW	WORKING PRESSURE	WEIGHT	LOCKING TORQUE
IC-162	1/2" + 3/4"	50 l./min.	320 bar	9.30 Kg.	6 Nm

Symbol

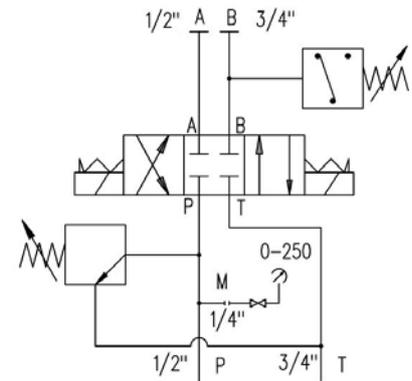

Description

Group for packing presses control.

Dimensions

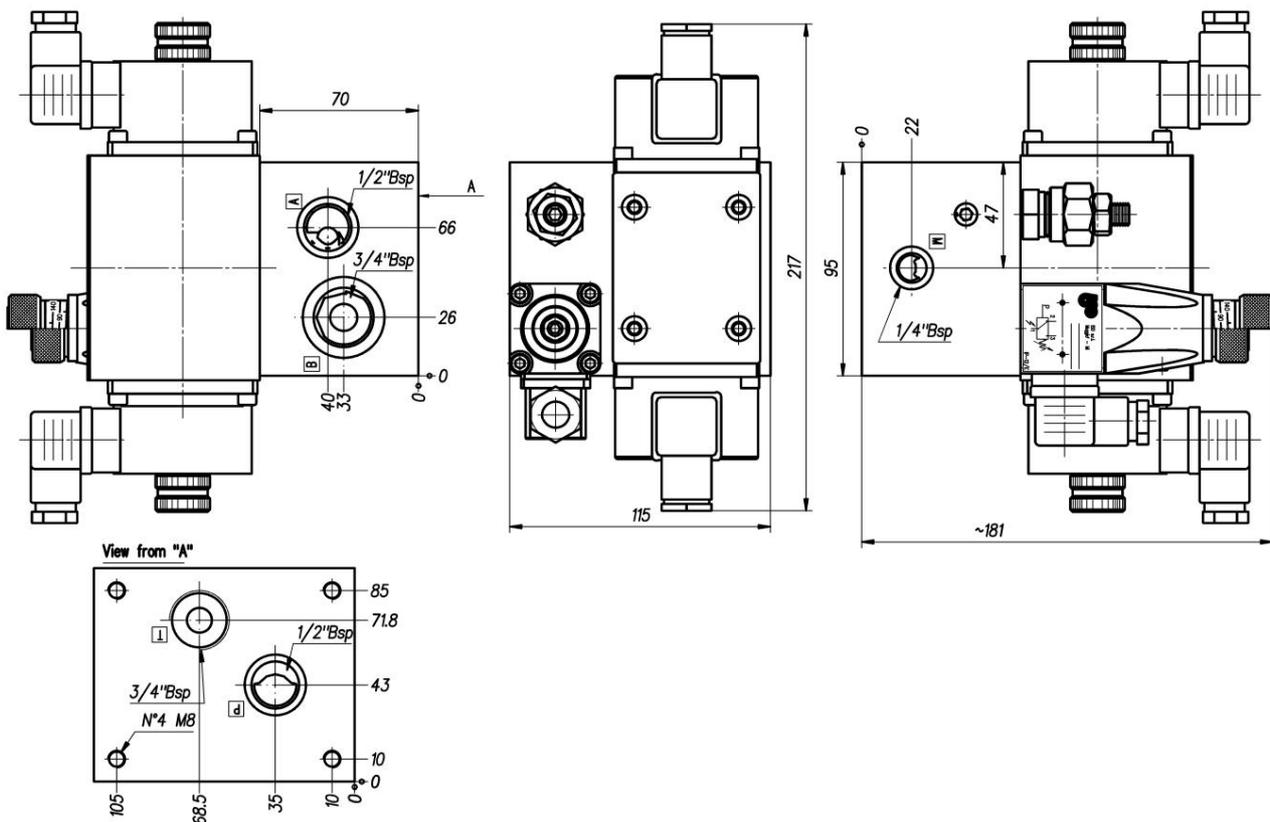

Installation rules

- IC-162 groups can be mounted in any position
- Fluid to be used: hydraulic oil in compliance with DIN 51524 rules, viscosity between 30 and 100 mm²/s (cSt) at 40°C
- Recommended filtration: 25µ
- Hydraulic fluid temperature: from -20° to +75°C

Ordering code

IC-162

Presses control block