

# SCREW IN MOUNTING CARTRIDGE CHECK VALVE

## Characteristics

TYPE	MAX FLOW	PRESSURE	LOCKING TORQUE	OPENING PRESSURE	WEIGHT
IC-1584	150 l./min.	420 bar	110 – 125 Nm	1 bar	Kg. 0.35

## Description

The screw in mounting cartridge check valves allow fluid passage in one direction and prevent it in the opposite one.

## Symbol



## Dimensions

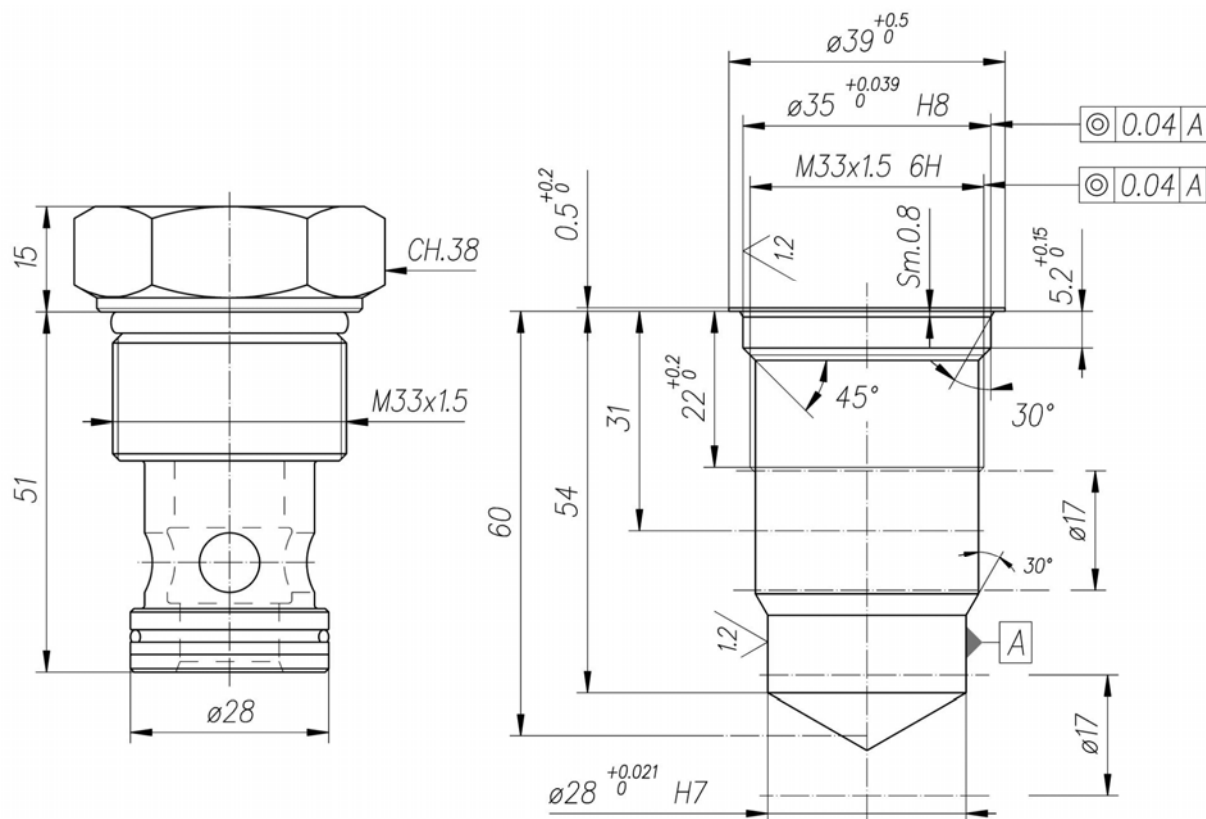

## Installation rules

- Installation: no orientations restrictions
- Fluid to be used: hydraulic oil in compliance with DIN 51524 rules, viscosity between 30 and 100 mm<sup>2</sup>/s (cSt) at 40°C
- Recommended filtration: 25μ
- Hydraulic fluid temperature: from -20° to +80°C

## Diagram

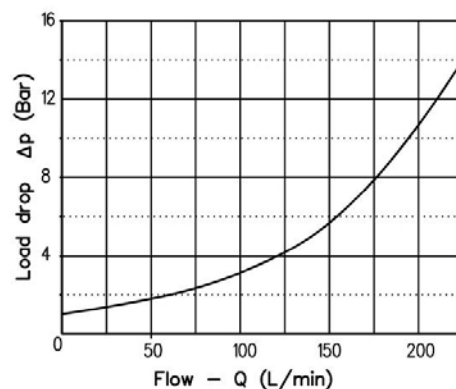

## Ordering code

IC-1584

Screw-in mounting cartridge check valve