

# TWO-WAY, SOLENOID OPERATED, PILOTED POPPET, CARTRIDGE VALVE



## Characteristics

TYPE	MAX FLOW	WORKING PRESSURE	WEIGHT (VASL) (Without coil)	WEIGHT (VASC) (Without coil)	Locking torque
VAS-**-16	240 lt./min.	Max. 350 Bar	Kg. 3.09	Kg. 0.51	Nm 200-215

## Description

Two-way, solenoid operated, piloted poppet, cartridge valves, NA (normally open) and NC (normally closed) version, with single or double check. They can be supplied with in-line body or as a cartridge (Cavity 16A-2) to be used mounted on integrated manifolds.

## Symbol

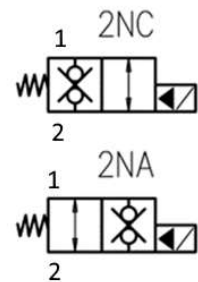

## Dimensions

### VASL

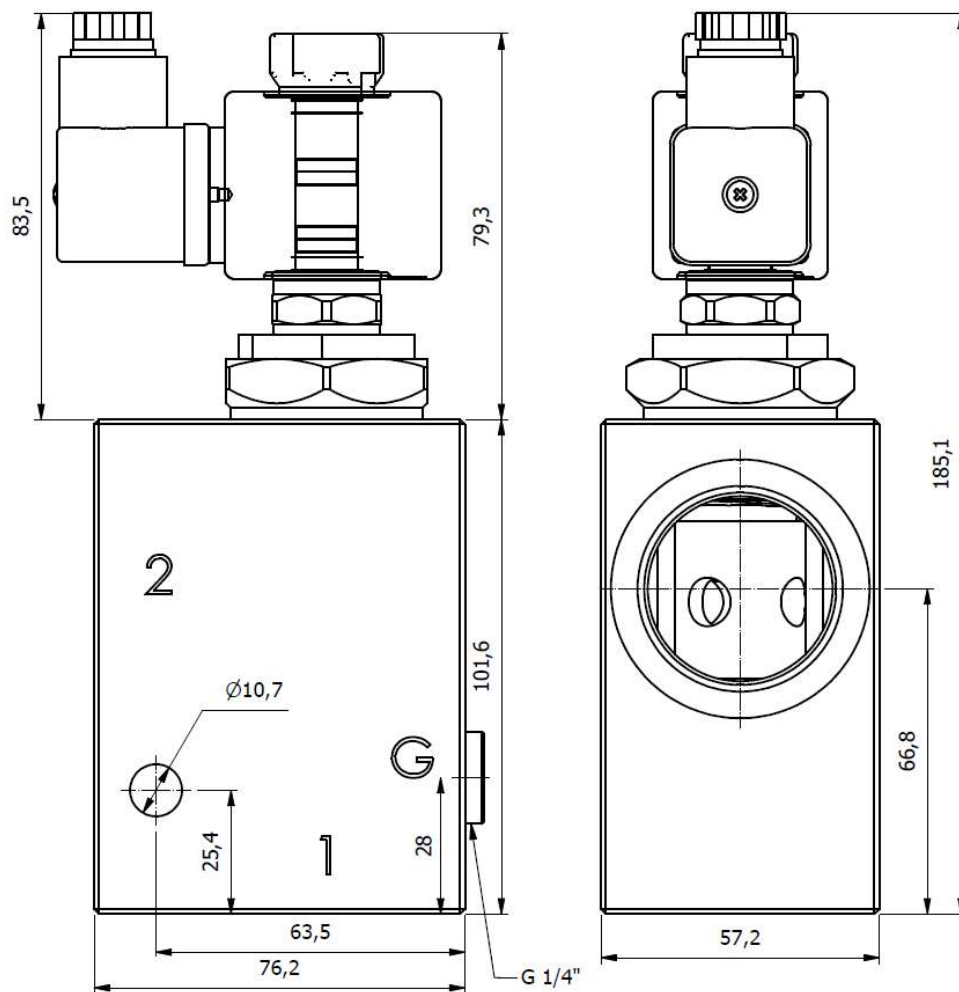

# TWO-WAY, SOLENOID OPERATED, PILOTED POPPET, CARTRIDGE VALVE



## VASC

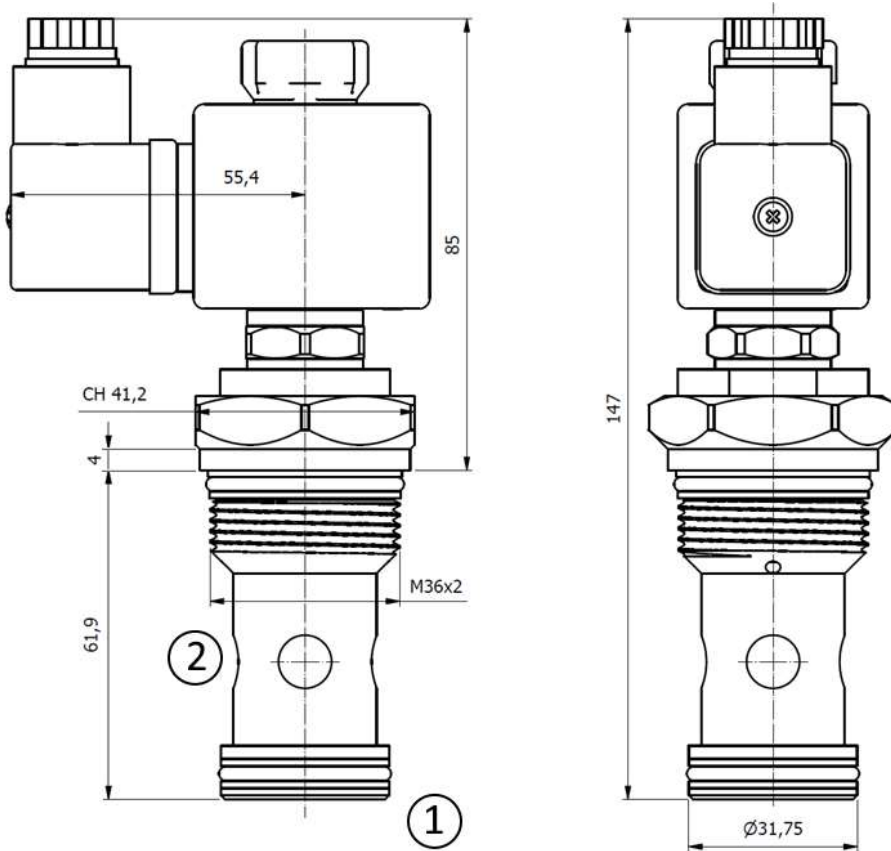

## Cavity 16A-2

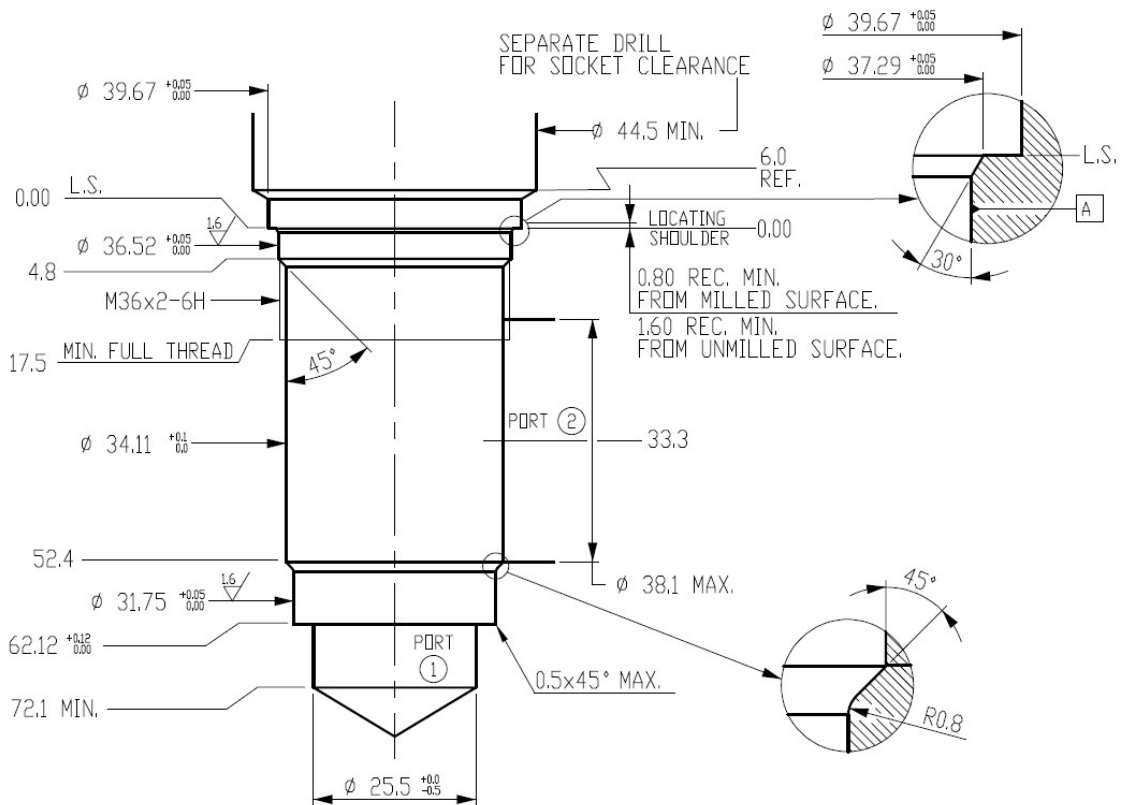

# TWO-WAY, SOLENOID OPERATED, PILOTED POPPET, CARTRIDGE VALVE



## Installation rules

- The valves VAS can be mounted in any direction
- Fluid to be used: hydraulic oil according to DIN 51524 with viscosity between 30 and 100 mm<sup>2</sup>/s (cSt) at 40°C
- Requested filtration degree: 25μ
- Hydraulic fluid temperature: from -20°C to +75°C

## Diagramm

### 2NA – 2NC

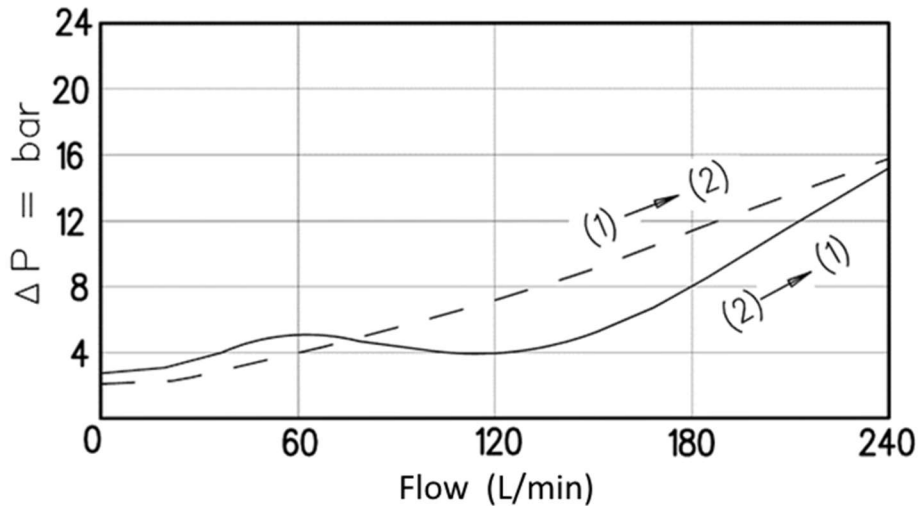

## Testing conditions :

- Fluid viscosity : VG46
- Fluid filtration : ISO 4406 15/13/11
- Fluid temperature: 40° C

## Coils :

## Electric characteristics

Code	Tension (V)	Current (A)		Protection Class	Power supply voltage variation	Ambient Temperature	Connection	Weight
		De-energized coil	Energized coil					
CVAS24R	24V RAC	0,95	0,63	Class H	+10% -10% Vnom	- 20 +50 °C	DIN-43650 ISO - 4400	0,22 Kg
CVAS110R	110V RAC	0,19	0,14					
CVAS220R	220V RAC	0,09	0,07					
CVAS10DC	10VDC	1,98	1,28					
CVAS12DC	12VDC	1,66	1,06					
CVAS14DC	14VDC	1,48	0,96					
CVAS20DC	20VDC	0,99	0,65					
CVAS24DC	24VDC	0,88	0,53					
CVAS26DC	26VDC	0,77	0,52					
CVAS28DC	28VDC	0,71	0,5					
CVAS36DC	36VDC	0,56	0,36					
CVAS48DC	48VDC	0,45	0,28					

# TWO-WAY, SOLENOID OPERATED, PILOTED POPPET, CARTRIDGE VALVE



## Ordering code

V	A	S	*	-	*	*	*	-	*	*	*	-	*	*	*	*	*	/	*								
<b>Two-way, solenoid operated, piloted poppet</b>																											
<b>C</b> = cartridge type <b>L</b> = in-line body <b>Type :</b> <b>NA</b> = Normally open <b>NC</b> = Normally closed <b>Ports (VASL) / Size (VASC)</b> <b>VASL</b> <b>114</b> = G 1"1/4 (A-B) <b>VASC</b> <b>16</b> = 16A-2 <b>Tension :</b> <b>24R</b> = 24V RAC <b>20DC</b> = 20VDC <b>110R</b> = 110V RAC <b>24DC</b> = 24VDC <b>220R</b> = 220V RAC <b>26DC</b> = 26VDC <b>10DC</b> = 10VDC <b>28DC</b> = 28VDC <b>12DC</b> = 12VDC <b>36DC</b> = 36VDC <b>14DC</b> = 14VDC <b>48DC</b> = 48VDC <b>Device for switching control:</b> <b>omit if</b> = no manual override (standard ) <b>P</b> = Push manual override (NA) <b>T</b> = Push and twist manual override (NA) <b>Seals:</b> <b>omit if</b> = NBR (standard ) <b>F</b> = FKM ( temp. - 20 °C + 80° C)			<table border="1"> <tr> <td>(STD)</td> <td></td> <td>T</td> <td></td> </tr> <tr> <td>P</td> <td></td> <td></td> <td></td> </tr> </table>																	(STD)		T		P			
(STD)		T																									
P																											

Ordering example :

- VASC-2NA-16-24DC
- VASL-2NC-114-110R