

CETOP-08 SIZE MODULAR CHECK VALVE



Characteristics

TYPE	FLOW	PRESSURE	WEIGHT
IRM-08/P	350 l/min.	320 bar	11 Kg.
IRM-08/T	350 l/min.	320 bar	11 Kg.

Description Cetop-08 size modular mounting check valve.

Dimensions

Type IRM-08/P

Symbol

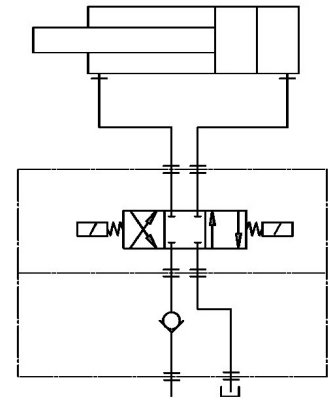
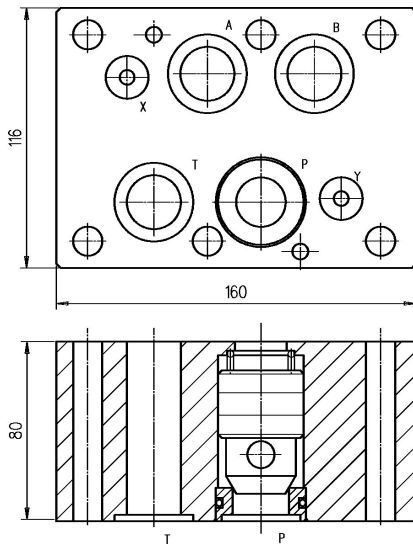

Dimensions

Type IRM-08/T

Symbol

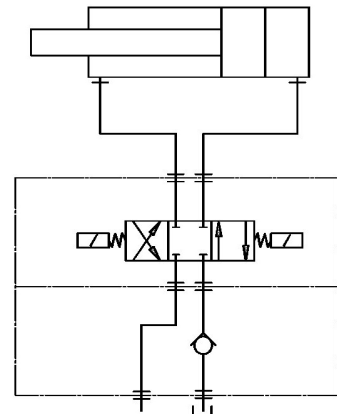
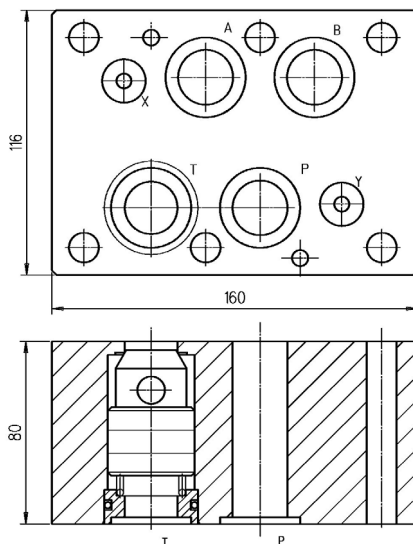

Ordering code

IRM-08 / *
 P=check on P port T=check on T port
 CETOP-08 size modular check valve

Installation rules

- The valves type IRM can be mounted in any position
- Fluid to be used: hydraulic oil in compliance with DIN 51524 rules, viscosity between 30 and 100 mm²/s (cSt) at 40°C
- Recommended filtration of 25µ
- Hydraulic fluid temperature: from -20° to +75°C