

CETOP-03 SIZE LEVER-OPERATED DISTRIBUTOR



Characteristics

TYPE	Max pressure		Suggested max flow	Weight
	P - A - B	T		
DCB-03-**-*	350 bar	160 bar	50 l/min	1.3 Kg.

Description

Cetop-03 size, lever-operated, four-way, two or three- position, spool distributor.

Dimensions

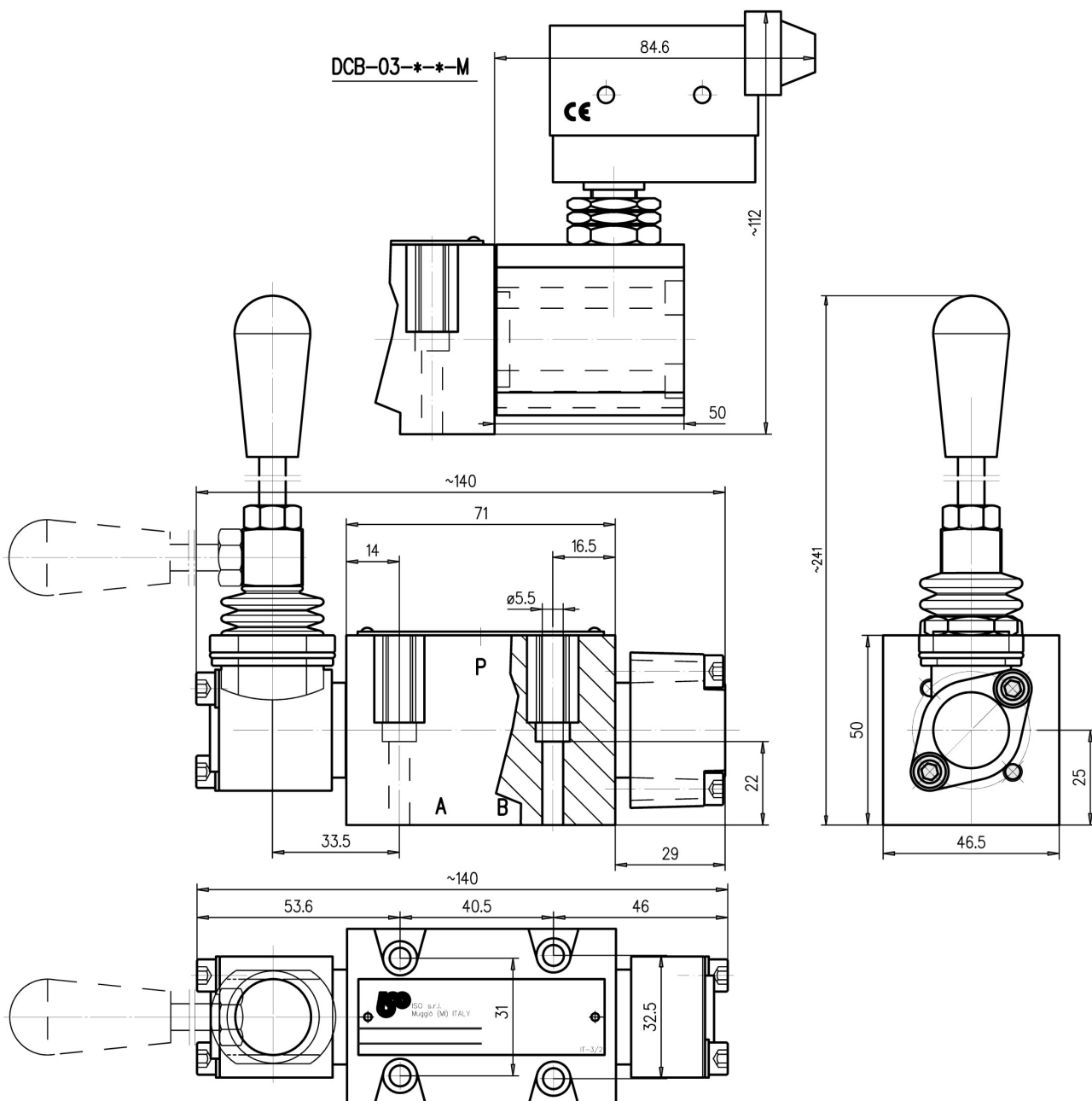

CETOP-03 SIZE LEVER-OPERATED DISTRIBUTOR



“A” TABLE

Type of control	
1	<p>3 positions, spring return to the center position</p>
2	<p>2 positions-spring return to the internal position</p>
2/A	<p>2 positions-spring return to the internal position</p>
4	<p>3 positions – with detent in three position</p>
5	<p>2 positions – with detent in two positions</p>
6	<p>2 positions – with detent in two positions</p>
6/A	<p>2 positions – with detent in two positions</p>
8	<p>2 positions, spring return to the center position</p>
8/A	<p>2 positions, spring return to the center position</p>

“B” TABLE

Type of spool	
0	
1	
3	
4	
5	
6	
7	

CETOP-03 SIZE LEVER-OPERATED DISTRIBUTOR



Installation rules

- The distributors type DCB-03 can be mounted in any position
- Fluid to be used: hydraulic oil in compliance with DIN 51524 rules, viscosity between 30 and 100 mm²/s (cSt) at 40°C
- Recommended filtration: 25μ
- Hydraulic fluid temperature: from -20° to +75°C

Ordering code

