

OIL FILLING AND FILTERING UNIT



Characteristics

TYPE	PUMP FLOW RATE	MOTOR CHARACTERISTICS	RETURN FILTERING DEGREE	SUPPLY FILTERING DEGREE	WEIGHT
CTF-40/*	40 Lt./min. - 1500 rev/1'	Kw. 0.75 4 Poles V.220/330 50 Hz.	10 μ /25 μ	125 μ	Kg. 53.5

Description Filtering and filling/emptying unit for hydraulic circuits. It is particularly useful for maintenance and starting operations of a plant. It is equipped with 2-metre length flexible piping equipped with rigid terminals and electric box in compliance with EC rules.

Dimensions

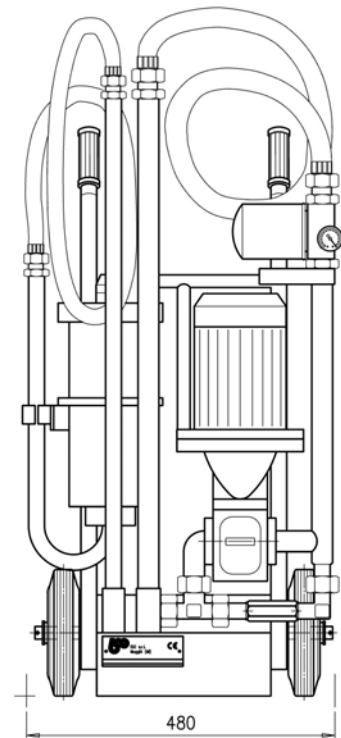
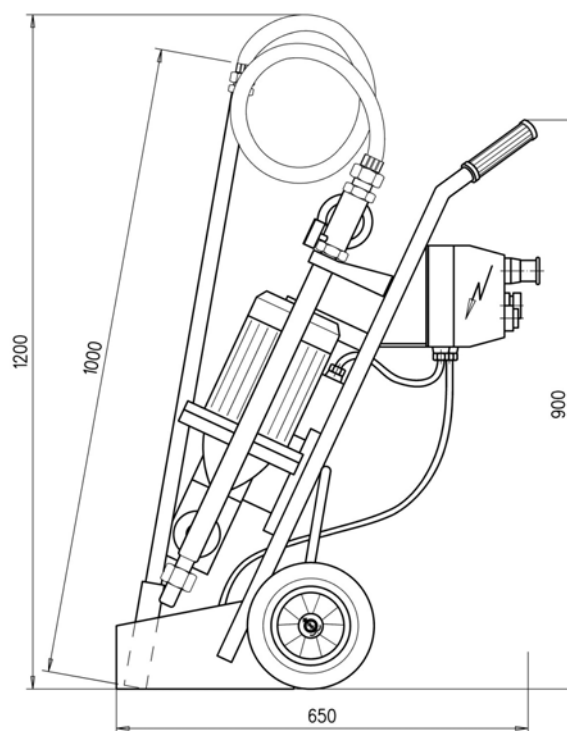

Hydraulic scheme

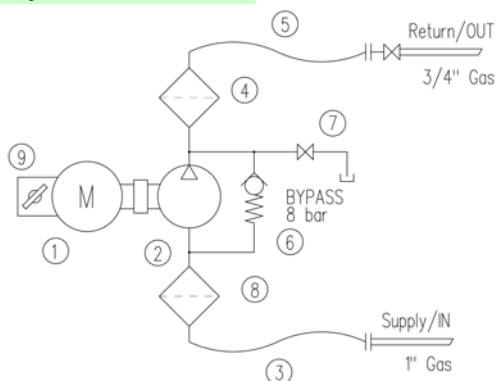

Pos.	Description	Code
1	Motor	0.75 Kw. - 4Poles V220/330 50Hz
2	Gear pump	Group 2 - 26 cm ³ /rev 40 Lt.
3	Suction hose	1" BSP L=2000
4	Return filter	MRH70-0-F*1-F10/D1
5	Feeding hose	3/4" BSP L=2000
6	Check valve	VR-38/8
7	Needle valve	FT-291-14
8	Suction filter	AMF-15E11S1-10/1E-MCV1
9	Electric box (compliance EC rules)	LG7 K06Q707

Ordering code

CTF - 40 / *	
	Filtering degree : 10 = 10 μ 25 = 25 μ
	Pump capacity 40 L/1'
	Oil filling and filtering unit